

**Southwest Microwave, Inc.**  
Security Systems Division

---

**INTREPID™**

**Alarm Input Module II**  
**Technical Manual**

---



## **Trademark Notice and Certifications**

INTREPID™, MicroPoint™ and MicroTrack™ are registered trademarks of Southwest Microwave, Inc. Copyright 1995 and 2011 Southwest Microwave, Inc. All rights Reserved.

### **FCC Notice**

This device complies with FCC Rules Part 15. Operation is subject to the following two conditions:

This device may not cause harmful interference and

This device must accept interference received, including interference that may cause undesired operation.

This equipment has been tested and found to comply with the limits for a Class A digital device, pursuant to part 15 of the FCC Rules. These limits are designed to provide reasonable protection against harmful interference when the equipment is operated in a commercial environment. This equipment generates, uses, and can radiate radio frequency energy and, if not installed and used in accordance with the instruction manual, may cause harmful interference to radio communications. Operation of this equipment in a residential area is likely to cause harmful interference in which case the user will be required to correct the interference at his own expense.

### **CE Notice**

This equipment has been designed and tested to EN61000-6-2:2005 and EN61000-6-4:2006 per Directive 89/336/EEC.

### **RoHS Compliant**

**Copyright Southwest Microwave, Inc. February, 2012**

**Southwest Microwave, Inc.  
9055 South McKemy Street  
Tempe, Arizona 85284-2946**

**Tel: (480) 783-0201**

**Fax: (480) 783-0401**

**Email: [infosd@southwestmicrowave.com](mailto:infosd@southwestmicrowave.com)**

**Web: [www.southwestmicrowave.com](http://www.southwestmicrowave.com)**

# Table of Contents

<b>1. Introduction.....</b>	<b>4</b>
<b>2. Hardware.....</b>	<b>4</b>
2.1 Alarm Input Module II.....	4
2.2 Optional Power Supplies .....	5
2.3 Interconnections.....	5
2.4 Typical Configuration.....	6
<b>3. Configuration Switches .....</b>	<b>7</b>
3.1 Introduction .....	7
3.2 Address Switch S1 .....	7
3.3 N.O./N.C State, Switch S2.....	8
3.4 Supervised and Un-Supervised State, Switch S4.....	8
3.5 Tamper Switch.....	9
<b>4. Configuring the AIM II.....</b>	<b>9</b>
4.1 Controller Devices .....	9
4.2 Setting the Address .....	9
4.3 Setting the Contact State.....	9
4.4 Setting the Supervised or Un-Supervised State .....	9

## 1.0 Introduction

The Alarm Input Module II (AIM II) is part of the INTREPID™ family of products. Its function is to monitor contact closures from other sensors that are not part of the INTREPID Series communications. It has eight (8) inputs and each input has an associated LED to indicate when the contact closure has an alarm condition. LED's are also provided for communications and power status. A system controller such as the Relay Control Module II (RCM II), Control Module II (CM II), Graphic Control Module II (GCM II), Perimeter Security Manager (PSM) or SDK (Software Development Kit) is required to individually configure the inputs of the AIM II.

Each input can be configured to a Normally Open (N.O.) or a Normally Closed (N.C.) state by means of a dip switch on the circuit board. Each input can also be configured to a Supervised or Unsupervised state by means of a dip switch on the circuit board.

The AIM II communicates with other INTREPID Series II devices using RS422 communications. This communication can be done over 22 or 24 gauge stranded shielded twisted pair wire (max 5,000 feet [1,500m] between devices) or fiber optic devices. The address of the AIM II is set by a dip switch on the circuit board.

The AIM II operates from 10.5 to 60 VDC @ 2.2 Watts with a minimum startup current of 190mA. The operating current with standard power supplies are: 12 VDC @ 100mA, 24 VDC @ 56mA and 48 VDC @ 36mA.

## 2.0 Hardware

### 2.1 Alarm Input Module II (AIM II)

The AIM II accepts contact closures from other devices such as microwave sensors, infrared sensors and gate switches that can be programmed to outputs by an INTREPID Series II system controller.

The AIM II is packaged in the standard INTREPID enclosure as shown in Figure 1. The dimensions are 5.5 in H x 13.5 in W x 5 in deep (14cm H x 34.3cm W x 12.7cm D). It weighs 2.5 lbs (1.1kg). The AIM II circuit board also has perforated ends that can be cut off to fit the board into a smaller or other enclosure.



*Figure 1 – INTREPID Enclosure for AIM II*

## 2.2 Optional Power Supplies

**12 VDC power supply:** Model PS13 Power Supply operates from 85-246VAC, 47-63Hz and furnishes 13.6 VDC at up to 2.8A. Power supplies contain automatic switchover and battery charging circuitry for optional standby batteries of up to 25AH. Temperature rated from 14° to 122° F (-10° to 50° C). UL, ETS, EMC, CE, RoHS compliant.

**12 VDC power supplies:** Model PS40 Power Supply operates from 120 VAC, 50-60Hz, 0.5A and furnishes 13.7 VDC at up to 1.6A. Model PS41 Power Supply operates from 220 VAC, 50-60Hz, 0.25A. Both contain automatic switchover and battery charging circuitry for optional standby batteries of up to 25AH and are fused on both input and output for maximum protection. Temperature rated from -40° to 150° F (-40° to 66° C).

**24 VDC power supply:** Model 78B1064 operates from 120VAC to provide 24VDC at 5A with 6.5AH battery backup. Includes; indoor enclosure 15 x 11 x 4 in. (381 x 280 x 102mm). Temperature rated from 32° to 122° F (0° to 50° C).

**48 VDC power supplies:** Model PS48 operates from 120VAC to provide 48VDC at 3A. Includes; indoor enclosure 14 x 12 x 4 in. (356 x 305 x 102mm). Model PS49 operates from 220VAC to provide 48VDC at 3A. *This supply does not include enclosure.* Temperature rated from 32° to 122° F (0° to 50° C). UL, CSA, TUV, CE compliant.

## 2.3 Interconnections

Figure 2 shows the various connection points, dip switches and diagnostic LED's available on the AIM II circuit board assembly.

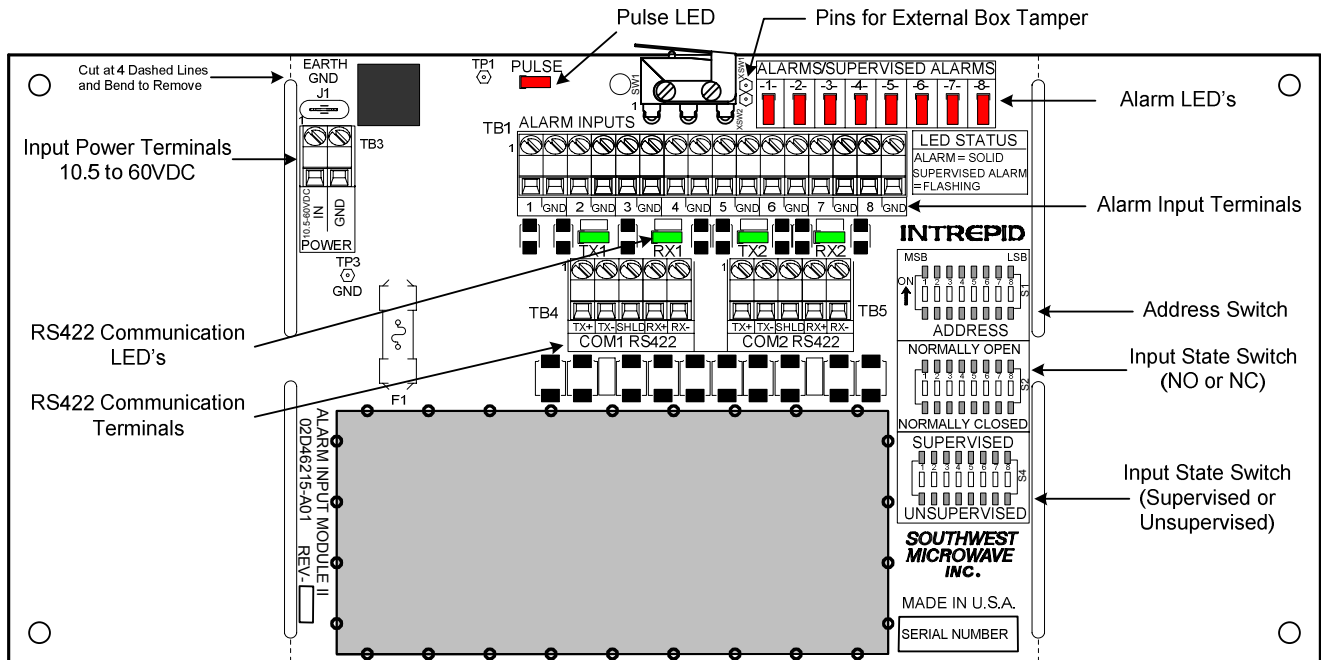

Figure 2 – Alarm Input Module II (AIM II) Circuit Card

Figure 3 shows the typical RS422 wiring diagram. This example uses the Relay Control Module II (RCM II) as the system controller connected to a Relay Output Module II-16 (ROM II-16), AIM II and a MicroTrack™ Processor II (MTP II). The AIM II and MTP II are located on the perimeter. The RCM II and the ROM II-16 are located in the control room for relay output interface to other control room devices.

The communications is RS422 and must use a 22 or 24 gauge twisted, stranded, shielded pair wire. Fiber optic devices can be used as well. Since this RS422 communications format is a point to point configuration, no termination device is required for the last unit on the line.

All the RS422 communications wiring is from the transmit side of one device to the receive side of the next device with the wiring from TX + to RX + and TX – to RX – as shown in Figure 3.

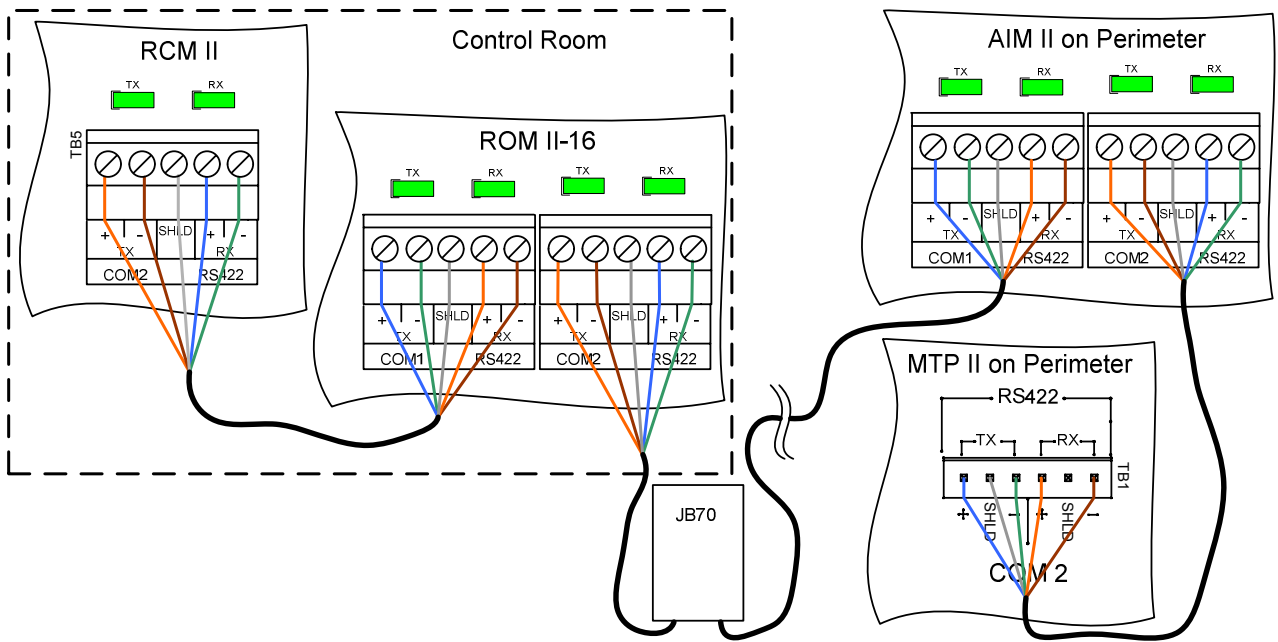

Figure 3 – AIM II Communications Wiring Diagram

## 2.4 Typical Configurations

Figure 4 shows a typical configuration using a RCM II, ROM II-16, AIM II, MTP II and a Microwave Link. The Control Room has a matrix switcher, lighting control system, paging system and an alarm panel. A computer is shown as the configuration/programming tool to set up the alarm structure (which is not needed for normal operation). The JB70A Surge/Lightning protection module is shown on the outside of the control room at the MTP II and at the AIM II. The RCM II, ROM II-16, AIM II and MTP II are connected together with the RS422 communications line. The Microwave Link alarm relay and tamper switches are wired into the AIM II. The RCM II and the ROM II-16 are programmed so their relay outputs trigger inputs on the alarm panel, lighting control system, pager system and CCTV matrix. A UPS is also shown and is recommended for backup of the INTREPID™ products.

The AIM II can also be used as a stand alone multiplex system gathering alarm and tamper contacts from various devices such as microwave sensors or infrared sensors. Connected to a controller and ROM II-8 or ROM II-16, the inputs can be programmed to outputs that can be connected to alarm panels or other alarm reporting devices.

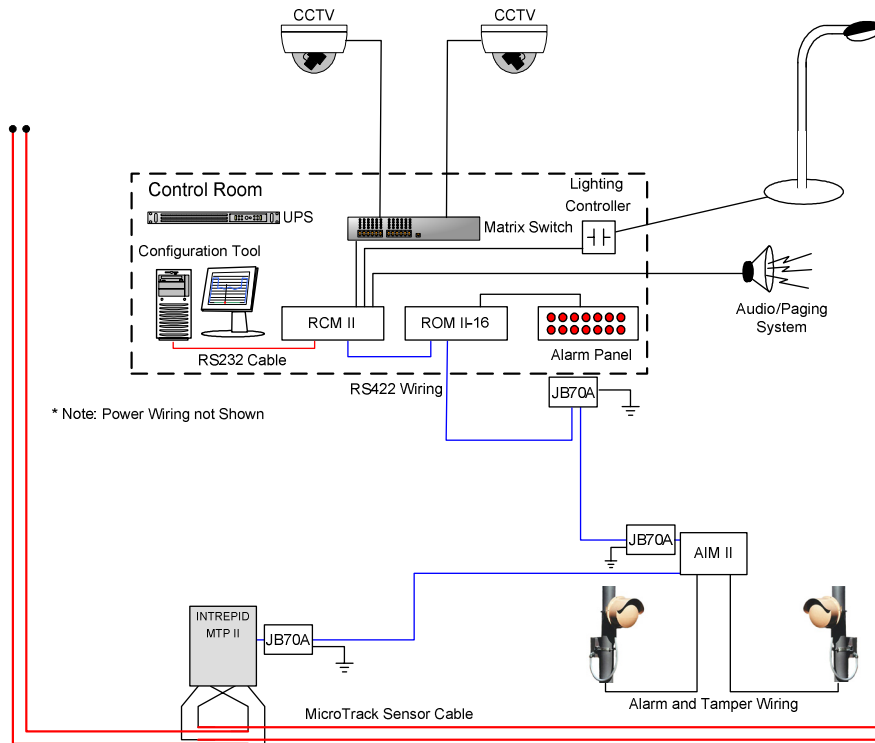

Figure 4 – Typical Configuration

### 3.0 Configuration Switches

#### 3.1 Introduction

There are three 8-position dip switches on the AIM-II; S1, S2 and S4. Switch S1 is used to set the address of the AIM-II. This address is used for alarm polling by one of INTREPID™ Series II controllers. Switch S2 is used to set the contact input to a Normally Open (N.O.) or Normally Closed (N.C.) state. Switch S4 is used to set the contact to a Supervised or Un-Supervised state.

#### 3.2 Address Switch S1

Switch S1 is used to set the address of the AIM II which is used for the alarm polling by one of the INTREPID Series II controllers (RCM II, CM II, GCM II, PSM or SDK). The address can be set from 0 to 239. Switch S1, as shown in Figure 5, is set by using the **LSB (Least Significant Bit)** as the binary reference starting point for address 1.

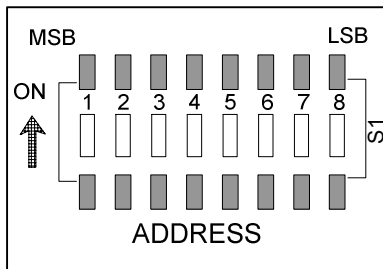

Figure 5 – Address Switch S1

### 3.3 N.O/N.C State, Switch S2

Switch S2 is used to set any contact input to a Normally Open (N.O.) or Normally Closed (N.C.) state as shown in Figure 6. When set to the Normally Open state, an alarm will be generated when the contact closes on the monitored contact. When set to the Normally Closed state, an alarm will be generated when the contact opens on the monitored contact. The red alarm LED for that input will illuminate in either of these two states.

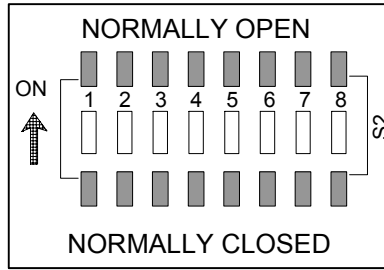

Figure 6 – Normally Open/Normally Closed State Switch S2

### 3.4 Supervised and Un-Supervised State, Switch S4

Switch S4 is used to set any contact input to a Supervised or Un-Supervised state as shown in Figure 7. When set to the Un-Supervised state, alarms will be generated as described in Section 3.3. When set to the ‘Supervised’ state (ON), a set of resistors (*not supplied*) mounted to the contact being monitored will be required as shown in Figure 8.

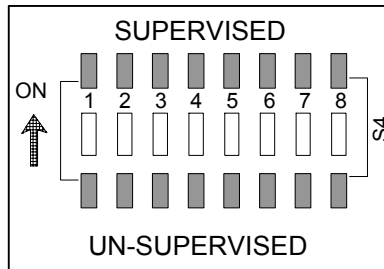

Figure 7 – Supervised/Un-Supervised State Switch S4

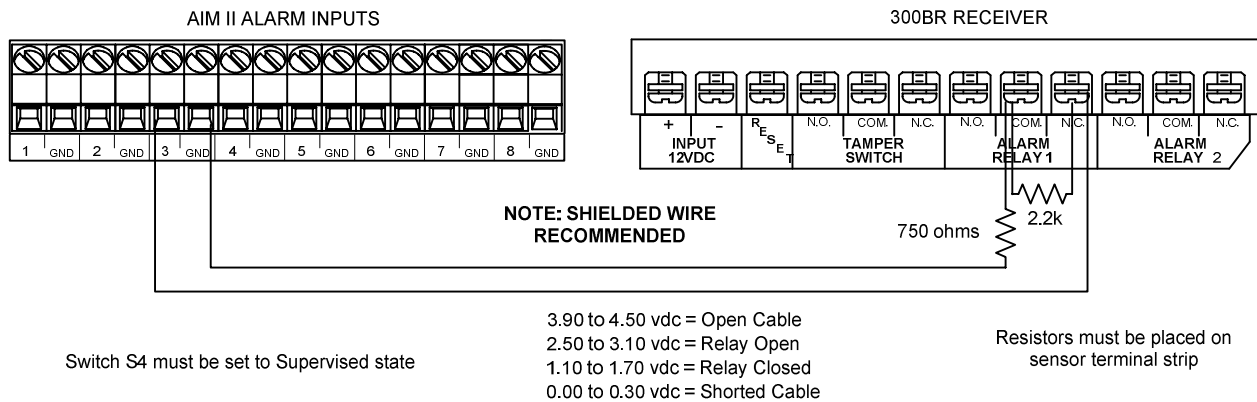

Figure 8 – Supervised Wiring Diagram



In the Supervised state alarms will be generated as described in Section 3.3. In addition to the normal alarm condition, the resistors installed on the monitored contact will provide a Supervised alarm if wires between the contact output and the AIM II input are shorted or opened. The red alarm LED will indicate a ‘Supervised’ alarm by a flashing LED.

### **3.5 Tamper Switch**

A tamper switch is located at the top of the circuit board (shown in Figure 2) and is activated when the enclosure lid is removed. If the AIM II is installed in a different enclosure, an external tamper switch can be connected to the two pins located immediately to the right of the on board switch. They are labelled XSW1 and XSW2. The external switch should be wired so that the contacts are shorted when the enclosure is closed.

## **4.0 Configuring the AIM II**

**Do not apply power until all communications wiring and dip switch settings have been configured.**

### **4.1 Controller Devices**

To configure the inputs of the AIM II to outputs of other INTREPID™ Series II products an INTREPID Series II controller device must be used. The available controller devices are: Relay Control Module II (RCM II), Control Module II (CM II), Graphic Control Module II (GCM II), Perimeter Security Manager (PSM) and a Software Development Kit (SDK).

### **4.2 Setting the Address**

Switch S1 sets the address for the AIM II. The address is set with the LSB (Least Significant Bit) as the starting point using the binary format 1, 2, 4, 8 etc. Set the appropriate switch(s) for the address required.

### **4.3 Setting the Contact State**

Switch S2 is used for setting the state of the contact being monitored to either Normally Closed (N.C.) or Normally Open (N.O.). If the contact being monitored is wired in a N.C. state then the S2 setting should be set to the N.C. position. Set all switches to the appropriate state.

### **4.4 Setting the Supervised or Un-Supervised State**

Switch S4 is used to set the contact to a Supervised or Un-Supervised state as described in Section 3.4. If a contact is to be supervised, two (2) resistors (750 ohm and 2.2K, ¼ W, 5%) will need to be connected at the contacts terminal points as shown in Figure 8. Set the switch(s) to the appropriate state.

Once all switches have been set and all communications wiring connected, apply power. Refer to the Controller Device Manual to program the inputs of the AIM II to outputs of a RCM II, CM II, ROM II-8 or ROM II-16.

